

## OWNERS MANUAL

# *dyno-matic*<sup>®</sup> drum pedal

Model #RP100

### Adjusting the 'Attack'

The Dyno-Matic features an option for the player to add a faster attack to the pedal response. With the Drum Key, loosen the set screw in the surface of the heel plate (shown below). Slide the pedalboard back, away from the frame. Only pull the pedalboard back until the Beater starts to move, then tighten the screw securely. You'll notice that the chain is now on an angle, and the response will feel a bit 'snappier' and faster when you play.

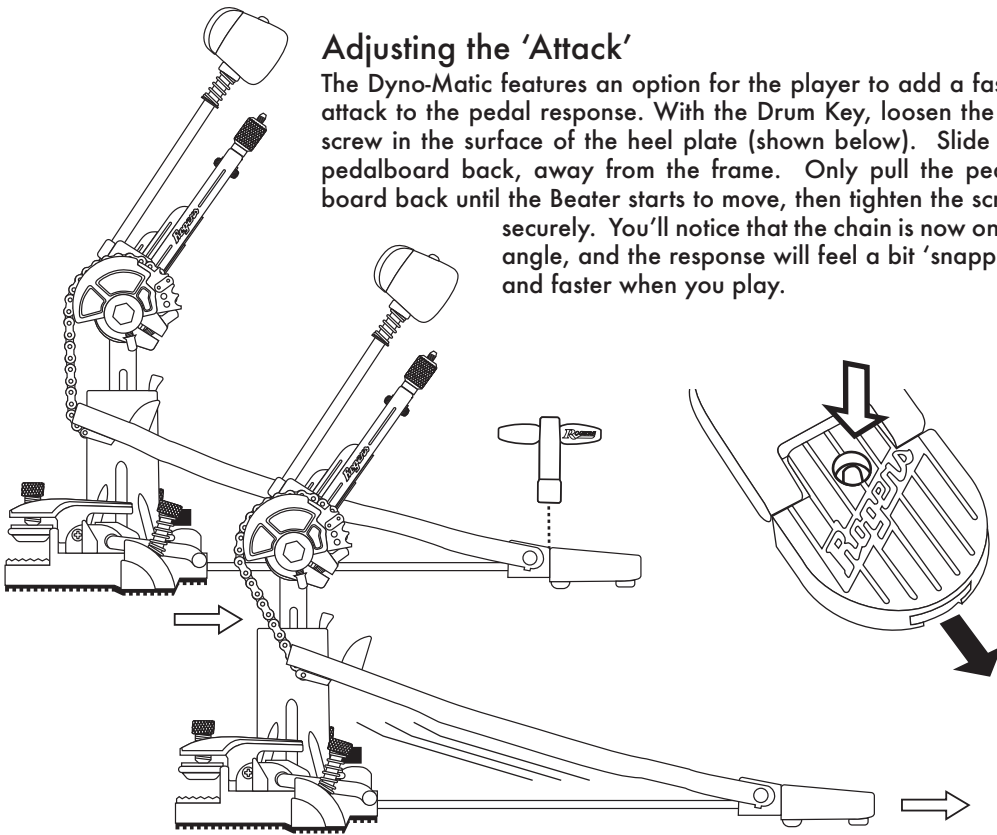

### Performance Tip - The Importance of Alignment

Bad alignment of the Beater & Chain Cams can affect performance. After adjusting the pedal components, view the axle straight-on to make sure the cams are aligned correctly.

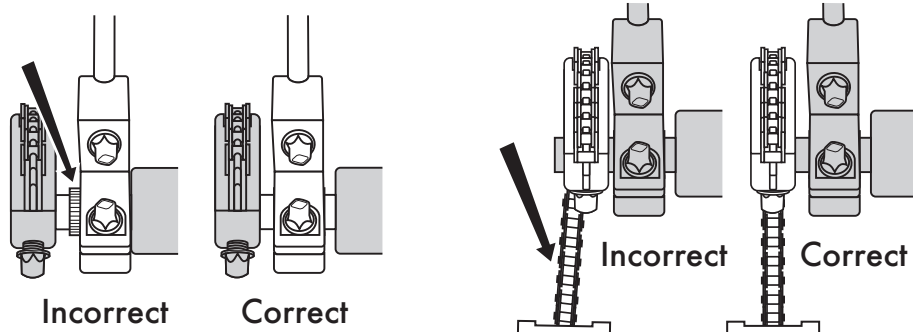

The Beater Cam should be centered on the knurled axle bushing.

The Chain Cam, Chain & Pedalboard should all be in a straight line.

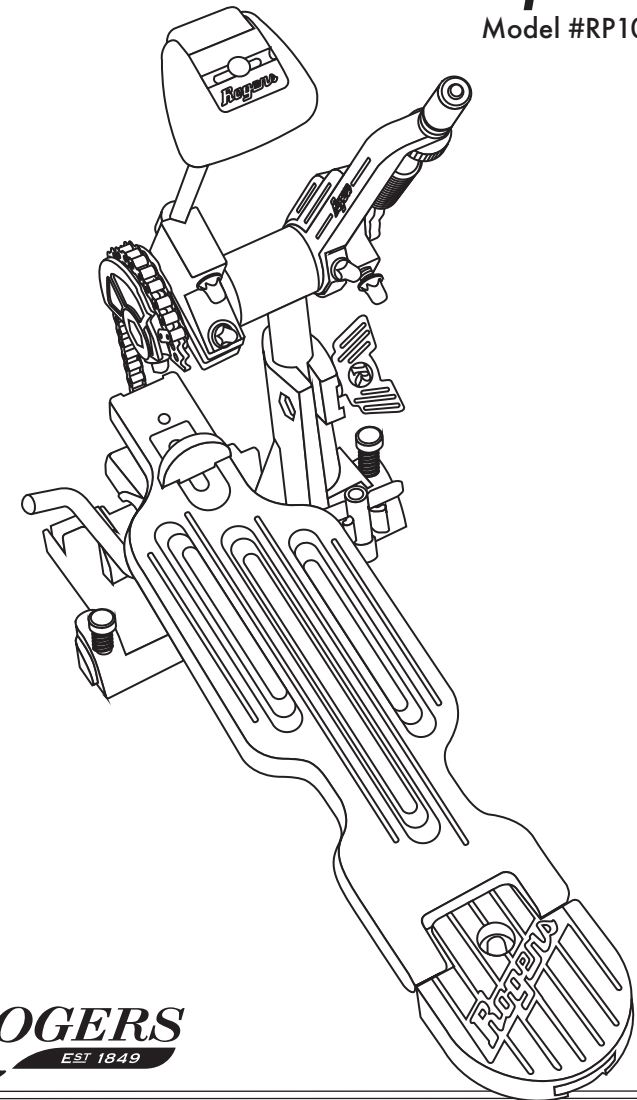

**ROGERS**  
EST 1849

CLASSIC  
**ROGERS**  
EST 1849  
INNOVATION

RogersDrumsUSA.com

**ROGERS**  
EST 1849

# *dyno-matic* drum pedal

Congratulations on your new Rogers Dyno-Matic Pedal. The Dyno-Matic is an extremely versatile bass drum pedal that offers seemingly endless options in performance adjustments. This pedal is designed to suit a diverse variety of player preferences, and also has the unique ability to adapt to a wide range of different size drums. Featuring independently-adjustable components like the Beater Cam, Spring Arm and Pedalboard/Axle positioning, the Dyno-Matic gives the player control over several different dynamic combinations at once. The Dyno-Matic is engineered throughout for ease of operation - even the way the pedal attaches and releases from the drum is just a simple flip of a lever.

First, let us introduce you to some of the key components of the Dyno-Matic that feature important adjuster screws and control nuts you can use to tweak your pedal's response and positioning. Don't be surprised if you find the set-up out of the box to be just perfect the way it is - but with the Rogers Dyno-Matic, you'll know that you always have options to try something completely different...

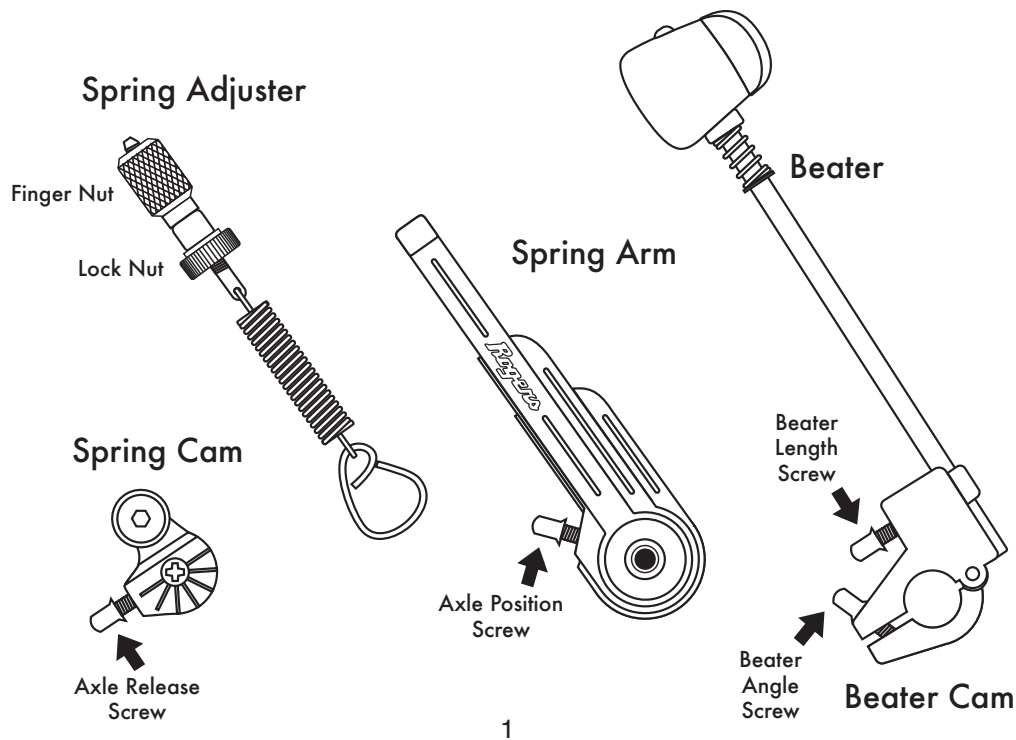

1

## Set the Height

For larger bass drums 22" - 30", you can raise the upper Axle Assembly as desired to center the Beater's strike on the drumhead.

1. Loosen the vertical shaft Wing Nut as shown.

2. Raise the Upper Axle Assembly by the chrome cylinder of the body. Tighten the Wing Nut securely at the desired height.

## Re-position Pedalboard & Beater

3. With the Drum Key, loosen the Axle Release Screw as shown to return the Pedalboard to your preferred playing position, then be sure to tighten the Axle Release Screw securely (IMPORTANT).

4. Use the Drum Key to loosen the Beater Angle Screw as shown to return the Beater to your preferred playing angle, then be sure to tighten the Beater Angle Screw securely.

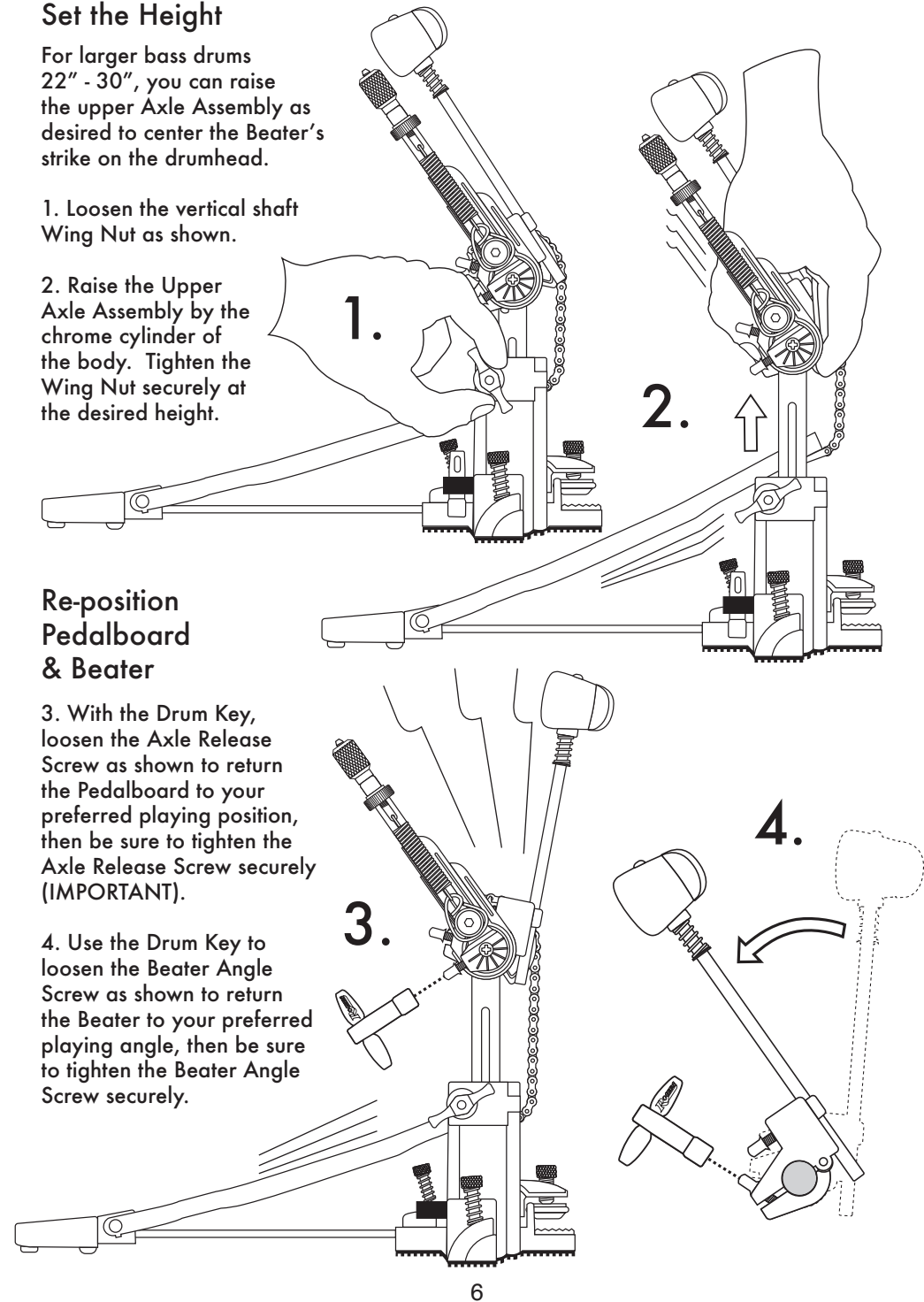

## What Size is Your Bass Drum?

Rogers created the idea of a pedal with a user-expandable height profile. This unique design allows the user to raise the main axle assembly - placing the Beater at the optimum striking position when used with any size bass drum.

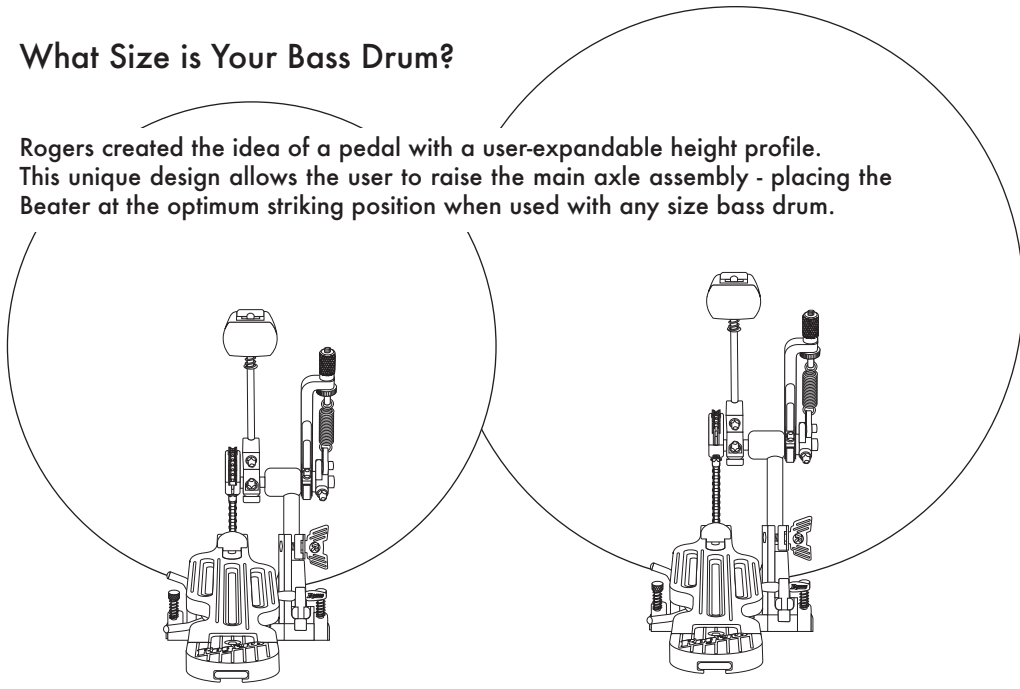

Out of the box, the Dyno-Matic is set at the lowest position, which will easily suit bass drums 18" - 20" (some may even prefer this setting for 22"). The main axle assembly of the Dyno-Matic is mounted on a single vertical shaft, which is adjustable in height to accommodate bass drum sizes from 18" up to 30". Because of the independent control of the Pedalboard position, the Beater Cam, and the Spring Arm, a player can maintain the comfort of their same familiar playing positions while also striking the 'sweet spot' of any size bass drum. See next page (6) for the simple procedure to adjust for different size bass drums.

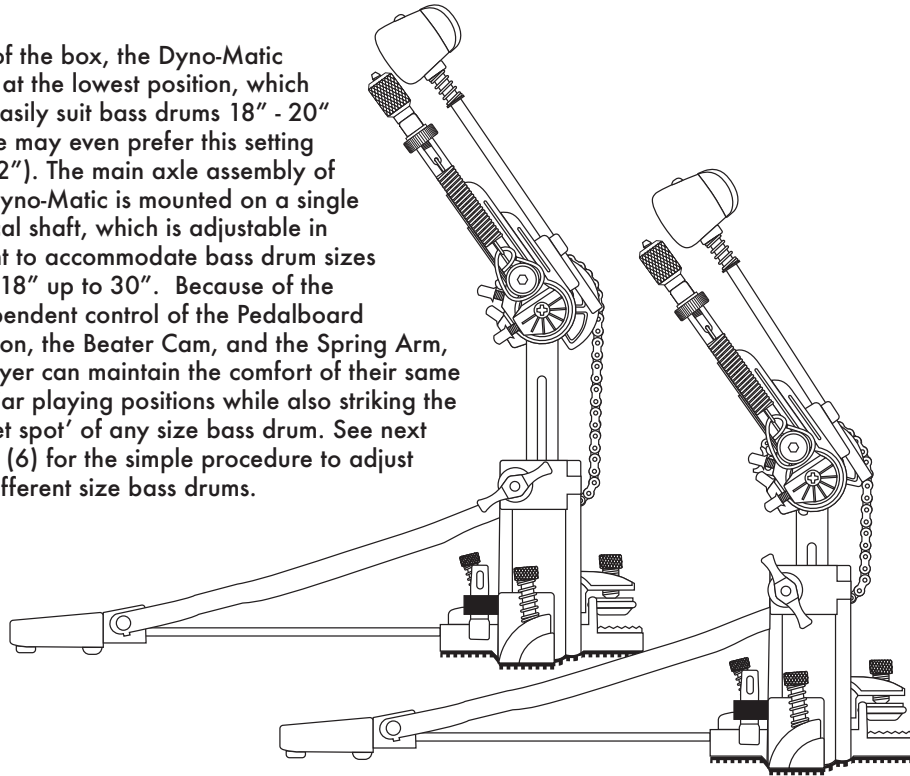

5

## OUT OF THE BOX

### Pedal Set-up

In the box, your Dyno-Matic Pedal has been collapsed for transport. It is easily adjusted for play using the following procedure. Locate the Drum Key mounted in the holder clip on the right side of the frame. Use the Drum Key to loosen the Axle Position Screw as shown above. Once loose, swivel the Spring Arm up to a comfortable angle, where you can easily reach it from your throne (the classic position shown at right, 55°). You will notice the Spring Arm, Beater and Pedalboard move together once the Axle Position Screw is released. Make sure to tighten the Axle Position Screw securely, and return the Drum Key to its holding clip on the pedal frame.

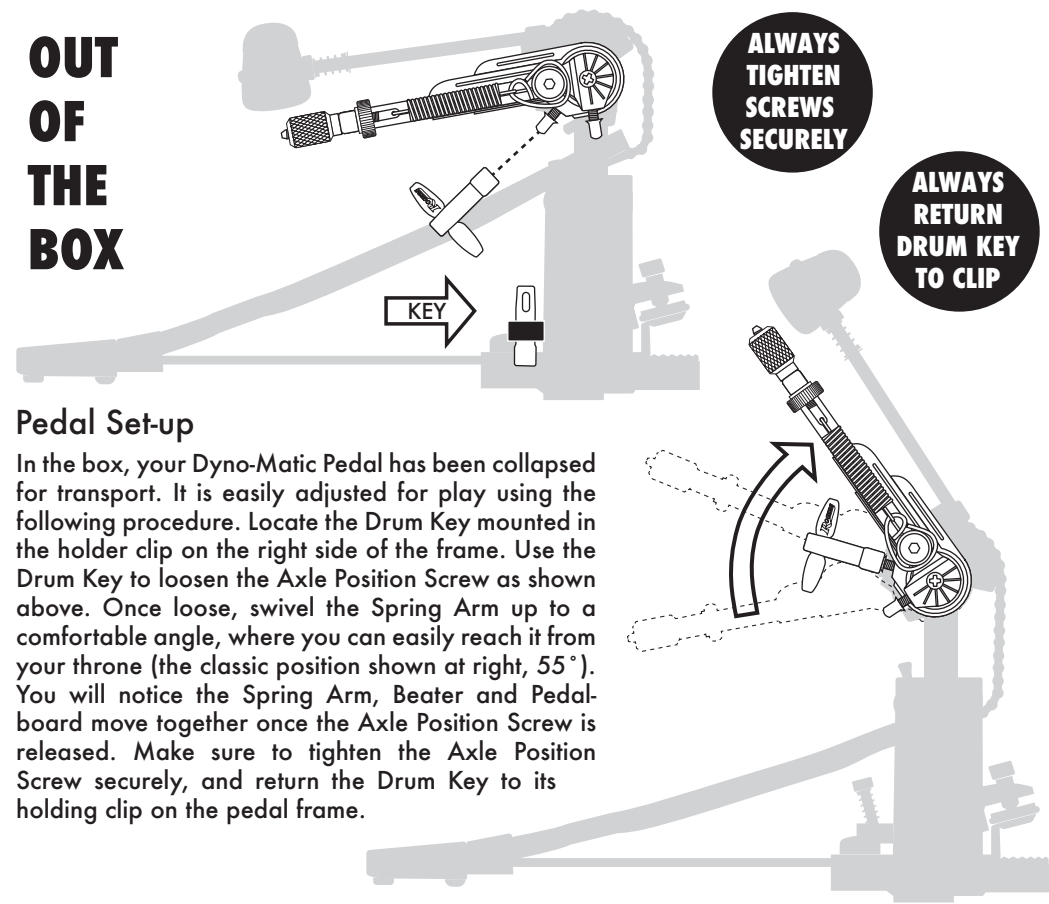

### Attaching the Pedal

The Dyno-Matic attaches to a bass drum hoop quickly & simply with the flip of the Hoop Clamp lever. With the Hoop Clamp open (lever down), insert the hoop fully into the clamp area as shown. Raise the lever all the way forward, until it snaps against the stop (as shown below).

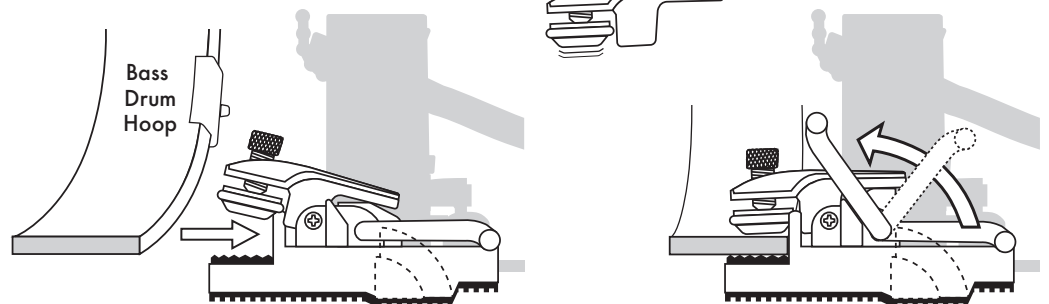

You can fine-tune how tightly the Hoop Clamp holds the hoop by adjusting the hoop tongue adjuster screw, as shown on the left.

2

## Quick-Flip Dual Surface Beater

Without any tools, you can instantly change the Beater playing surface from the standard felt side (muted tone), to the hard plastic side (crisp attack). Simply push down the spring loaded beater head and rotate it to the desired playing surface, and it snaps into place, ready to play.

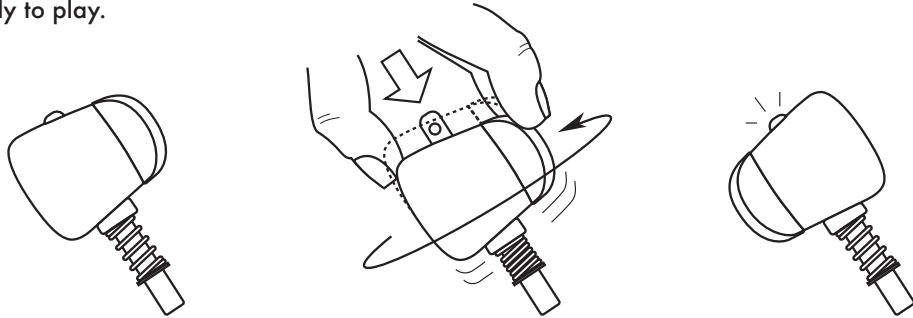

## Carpet Anchor Screws

The Dyno-Matic Pedal features a ribbed, rubber sole on the bottom of main pedal frame for maximum grip on smooth surfaces. For playing on carpeted surfaces, adjustable Anchor Screws are located on both sides of the pedal frame. Adjust with your fingers to extend the Anchors' pointed tips to "bite" into the carpet and prevent movement.



## Adjustable Toe-Stop

The optional Toe-Stop for the pedalboard can be easily adjusted forward or back (or removed) to suit the player's preference. Using the Drum Key, loosen the set screw underneath the pedalboard to change position. Tighten securely once in position.

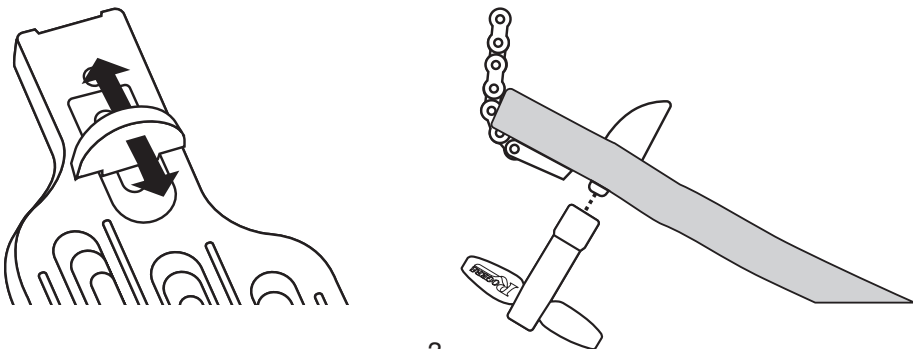

## Top-mounted, Spring Adjuster Arm

The Dyno-Matic features a modern upgrade to one of Roger's original pedal innovations - the top-mounted Spring Adjuster Arm. While playing the pedal, you can easily reach from your playing position to adjust the spring action with one hand.

First loosen the Lock Nut by turning clockwise. Then adjust the Finger Nut to loosen, or tighten the spring to achieve the desired 'feel'. Then, turn the Lock Nut counter-clockwise to set the position.

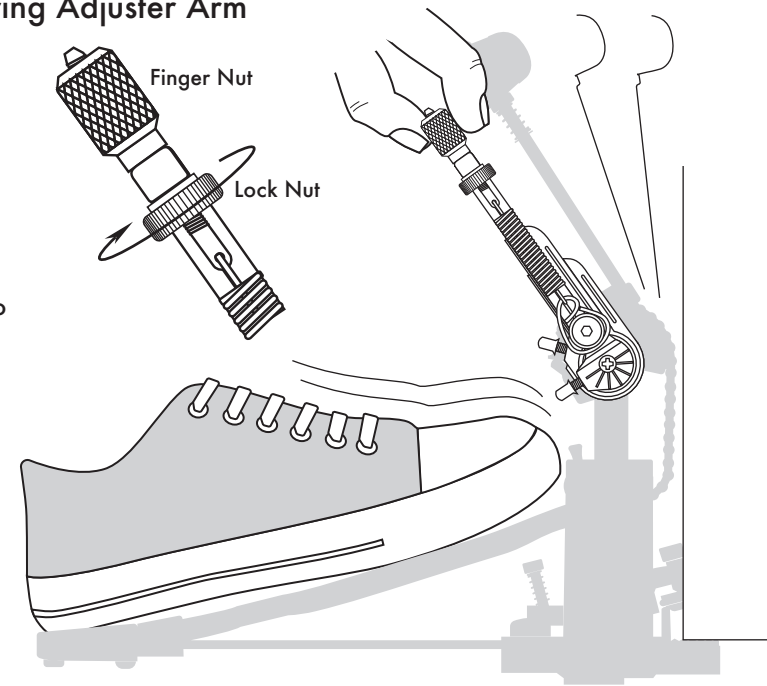

## Beater Position Adjustments

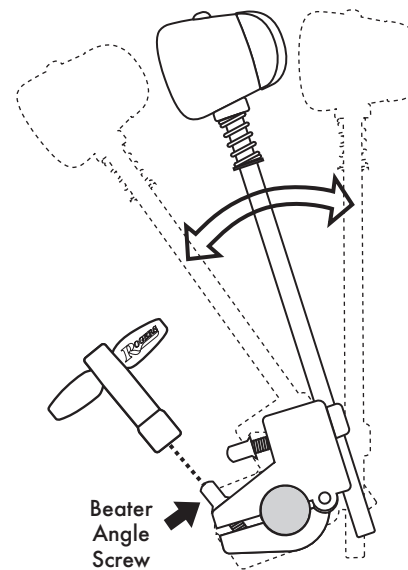

The Beater of the Dyno-Matic Pedal can be positioned independently - without affecting the positions of the Pedalboard, the Spring Arm, or the Axle height. The forward, or backward angle of the Beater Cam is adjusted by loosening the Beater Angle Screw with the Drum Key, as shown on the left. The length of the Beater shaft can be changed by loosening the Beater Length Screw with the Drum Key, as shown on the right. Be sure to tighten the screws securely once positioned.

